

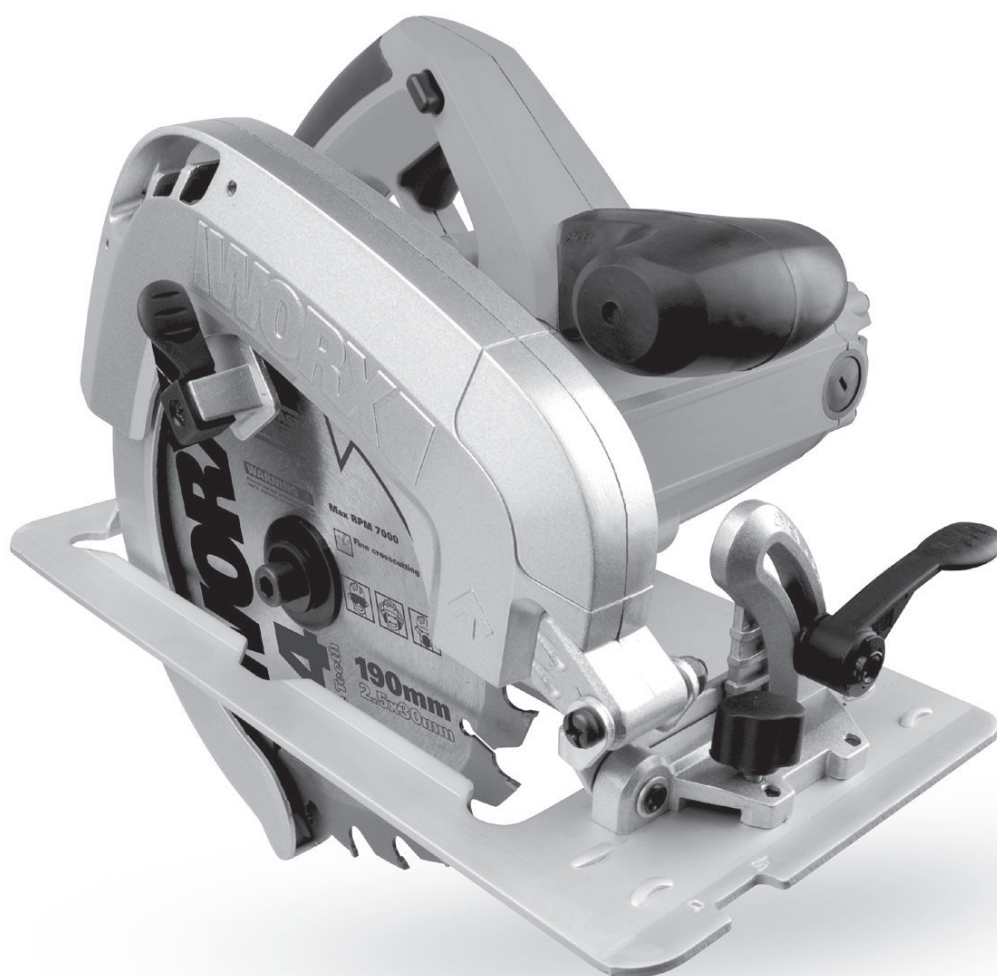

WORX



SAFETY AND OPERATING MANUAL

Circular saw

WX441 WX441.1

SAFETY INSTRUCTIONS



WARNING! Read all safety warnings and all instructions. Failure to follow the warnings and instructions may result in electric shock, fire and/or serious injury.

Save all warnings and instructions for future reference.

The term “power tool” in the warnings refers to your mains-operated (corded) power tool or battery-operated (cordless) power tool.

1) WORK AREA SAFETY

a) Keep work area clean and well lit.

Cluttered or dark areas invite accidents.

b) Do not operate power tools in explosive atmospheres, such as in the presence of flammable liquids, gases or dust.

Power tools create sparks which may ignite the dust or fumes.

c) Keep children and bystanders away while operating a power tool.

Distractions can cause you to lose control.

2) ELECTRICAL SAFETY

a) Power tool plugs must match the outlet. Never modify the plug in any way. Do not use any adapter plugs with earthed (grounded) power tools.

Unmodified plugs and matching outlets will reduce risk of electric shock.

b) Avoid body contact with earthed or grounded surfaces such as pipes, radiators, ranges and refrigerators.

There is an increased risk of electric shock if your body is earthed or grounded.

c) Do not expose power tools to rain or wet conditions.

Water entering a power tool will increase the risk of electric shock.

d) Do not abuse the cord. Never use the cord for carrying, pulling or unplugging the power tool. Keep cord away from heat, oil, sharp edges or moving parts.

Damaged or entangled cords increase the risk of electric shock.

e) When operating a power tool outdoors, use an extension cord suitable for outdoor use.

Use of a cord suitable for outdoor use reduces the risk of electric shock.

f) Recommendation for the use of a

residual current device with a rated residual current of 30 mA or less.

3) PERSONAL SAFETY

a) Stay alert, watch what you are doing and use common sense when operating a power tool. Do not use a power tool while you are tired or under the influence of drugs, alcohol or medication.

A moment of inattention while operating power tools may result in serious personal injury.

b) Use personal protective equipment. Always wear eye protection.

Protective equipment such as dust mask, non-skid safety shoes, hard hat, or hearing protection used for appropriate conditions will reduce personal injuries.

c) Prevent unintentional starting. Ensure the switch is in the off-position before connecting to power source and/or battery pack, picking up or carrying the tool.

Carrying power tools with your finger on the switch or energising power tools that have the switch on invites accidents.

d) Remove any adjusting key or wrench before turning the power tool on.

A wrench or a key left attached to a rotating part of the power tool may result in personal injury.

e) Do not overreach. Keep proper footing and balance at all times.

This enables better control of the power tool in unexpected situations.

f) Dress properly. Do not wear loose clothing or jewellery. Keep your hair, clothing and gloves away from moving parts.

Loose clothes, jewellery or long hair can be caught in moving parts.

g) If devices are provided for the connection of dust extraction and collection facilities, ensure these are connected and properly used.

Use of these devices can reduce dust-related hazards.

4) POWER TOOL USE AND CARE

a) Do not force the power tool. Use the correct power tool for your application.

The correct power tool will do the job better and safer at the rate for which it was designed.

b) Do not use the power tool if the switch

does not turn it on and off. Any power tool that cannot be controlled with the switch is dangerous and must be repaired.

- c) Disconnect the plug from the power source and/or the battery pack from the power tool before making any adjustments, changing accessories, or storing power tools.** Such preventive safety measures reduce the risk of starting the power tool accidentally.
- d) Store idle power tools out of the reach of children and do not allow persons unfamiliar with the power tool or these instructions to operate the power tool.** Power tools are dangerous in the hands of untrained users.
- e) Maintain power tools. Check for misalignment or binding of moving parts, breakage of parts and any other condition that may affect the power tools operation. If damaged, have the power tool repaired before use.** Many accidents are caused by poorly maintained power tools.
- f) Keep cutting tools sharp and clean.** Properly maintained cutting tools with sharp cutting edges are less likely to bind and are easier to control.
- g) Use the power tool, accessories and tool bits etc. in accordance with these instructions and in the manner intended for the particular type of power tool, taking into account the working conditions and the work to be performed.** Use of the power tool for operations different from those intended could result in a hazardous situation.

5) BATTERY TOOL USE AND CARE

- a) Ensure the switch is in the off position before inserting battery pack.** Inserting the battery pack into power tools that have the switch on invites accidents.
- b) Recharge only with the charger specified by the manufacturer.** A charger that is suitable for one type of battery pack.
- c) Use power tools only with specifically designated battery packs.** Use of any other battery packs may create a risk of injury and fire.
- d) When battery pack is not in use, keep it away from other metal objects like paper**

clips, coins, keys, nails, screw, or other small metal objects that can make a connection from one terminal to another.

Shorting the battery terminals together may cause burns or fire.

- e) Under abusive conditions, liquid may be ejected from the battery; avoid contact, if contact accidentally occurs, flush with water. If liquid contacts eyes, additionally seek medical help.** Liquid ejected from the battery may cause irritation or burns.

6) SERVICE

- a) Have your power tool serviced by a qualified repair person using only identical replacement parts.** This will ensure that that safety of the power tool is maintained.

ADDITIONAL SAFETY RULES FOR YOUR CIRCULAR SAW

1. Always wear a dust mask, hearing protection and eye protection.
2. Only use saw blades recommended in the specification.
3. Always wear gloves when handling saw blades and rough material. Saw blades shall be carried in a holder whenever practicable.
4. Fully unwind cable drum extension to avoid potential overheating.
5. When an extension cable is required you must ensure it has the correct ampere rating for your power tool and is in a safe electrical condition.
6. Ensure your mains supply voltage is the same as indicated on the rating plate.
7. Your circular saw is a hand held tool, do not clamp your circular saw.
8. Before cutting, check the cutting line is free of nails, screws, etc.
9. Do not cut small workpieces with a circular saw. If possible, use a jigsaw.
10. Only make cuts with the blade direction downwards, never upwards or at the side.
11. Do not use a blade unless the rated blade speed exceeds the saw no load speed.
12. Never remove the guard system. Never use the saw if the guard system does not

function correctly. Never lock the moving guard open. The guard must move freely.

13. Never use saw blades made from high speed steel(HSS).
14. Always check walls, floors and ceilings to avoid hidden power cable and pipes.
15. After long working periods external metal parts and accessories could be hot.
16. Do not cut material containing asbestos.
17. Do not use metal or stone saw blades. Only use wood saw blades.
18. Do not use circular saw to cut tree limbs or logs.
19. Do not use any abrasive wheels.



WARNING:

- a. Keep hands away from cutting area and the blade. Keep your second hand on auxiliary handle, or motor housing.** If both hands are holding the saw, they can not be cut by the blade.
- b. Do not reach underneath the work-piece.** The guard cannot protect you from the blade below the work-piece.
- c. Adjust the cutting depth to the thickness of the work-piece.** Less than a full tooth of the blade teeth should be visible below the work-piece.
- d. Never hold piece being cut in your hands or across your leg. Secure the work-piece to a stable platform.** It is important to support the work properly to minimize body exposure, blade binding, or loss of control.
- e. Hold power tool by insulated gripping surfaces when performing an operation where the cutting tool may contact hidden wiring or its own cord.** Contact with a "live" wire will also make exposed metal parts of the power tool "live" and shock the operator.
- f. When ripping always use a rip fence or straight edge guide.** This improves the accuracy of cut and reduce the chance of blade binding.
- g. Always use blades with correct size and shape (diamond versus round) of arbor holes.** Blades that do not match the mounting hardware of the saw will run eccentrically, causing loss of control.
- h. Never use damaged or incorrect blade washers or bolt.** The blade washers and

bolt were specially designed for your saw, for optimum performance and safety of operation.

FURTHER SAFETY INSTRUCTIONS FOR ALL SAWS CAUSES AND OPERATOR PREVENTION OF KICKBACK:

- Kickback is a sudden reaction to pinched, bound or misalign saw blade, causing an uncontrolled saw to lift up and out of the work-piece toward the operator;
- When the blade is pinched or bound tightly by the kerf closing down, the blade stalls and the motor reaction drives the unit rapidly back toward the operator;
- If the blade becomes twisted or misalign in the cut, the teeth at the back edge of the blade can dig into the top surface of the wood causing the blade to climb out of the kerf and jump back toward the operator.

KICKBACK IS THE RESULT OF SAW MISUSE AND/OR INCORRECT OPERATING PROCEDURES OR CONDITIONS AND CAN BE AVOIDED BY TAKING PROPER PRECAUTIONS AS GIVEN BELOW.

- a. Maintain a firm grip with both hands on the saw and position your arms to resist kickback forces. Position your body to either side of the blade, but not in line with the blade.** Kickback could cause the saw to jump backwards, but kickback forces can be controlled by the operator, if proper precautions are taken.
- b. When blade is binding, or when interrupting a cut for any reason, release the trigger and hold the saw motionless in the material until the blade comes to a complete stop. Never attempt to remove the saw from the work or pull the saw backward while the blade is in motion or kickback may occur.** Investigate and take corrective actions to eliminate the cause of blade binding.
- c. When restarting a saw in the work-piece, center the saw blade in the kerf and check that saw teeth are not engaged into the material.** If saw blade is binding, it may walk up or kickback from the work-piece as the saw is restarted.
- d. Support large panels to minimize the**

risk of blade pinching and kickback.

Large panels tend to sag under their own weight. Supports must be placed under the panel on both sides, near the line of cut and near the edge of the panel.

- e. Do not use dull or damaged blades.** Unsharpened or improperly set blades product narrow kerf causing excessive friction, blade binding and kickback.
- f. Blade depth and bevel adjusting locking levers must be tight and secure before making cut.** If blade adjustment shifts while cutting, it may cause binding and kickback.
- g. Use extra caution when making a "plunge cut" into existing walls or other blind areas.** The protruding blade may cut objects that can cause kickback.

SAFETY INSTRUCTION FOR CIRCULAR SAW WITH INNER PENDULUM GUARD

- a. Check lower guard for proper closing before each use. Do not operate the saw if lower guard does not move freely and close instantly. Never clamp or tie the lower guard into the open position.** If saw is accidentally dropped, lower guard may be bent. Raise the lower guard with the retracting handle and make sure it moves freely and does not touch the blade or any other parts, in all angles and depths of cut.
- b. Check the operation of the lower guard spring. If the guard and the spring are not operating properly, they must be serviced before use.** Lower guard may operate sluggishly due to damaged parts, gummy deposits, or a build-up of debris.
- c. Lower guard should be retracted manually only for special cuts such as "plunge cuts" and "compound cuts". Raise lower guard by retracting handle and as soon as blade enters the material, the lower guard must be released.** For all other sawing, the lower guard should operate automatically.
- d. Always observe that the lower guard is covering the blade before placing saw down on bench or floor.** An unprotected, coasting blade will cause the saw to walk backwards, cutting whatever is in its path. Be aware of the time it takes for blade to stop after switch is released.

SYMBOLS



To reduce the risk of injury, user must read instruction manual

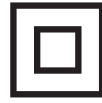

Double insulation



Warning



Wear ear protection



Wear eye protection



Wear dust mask



RCM approval mark

5112

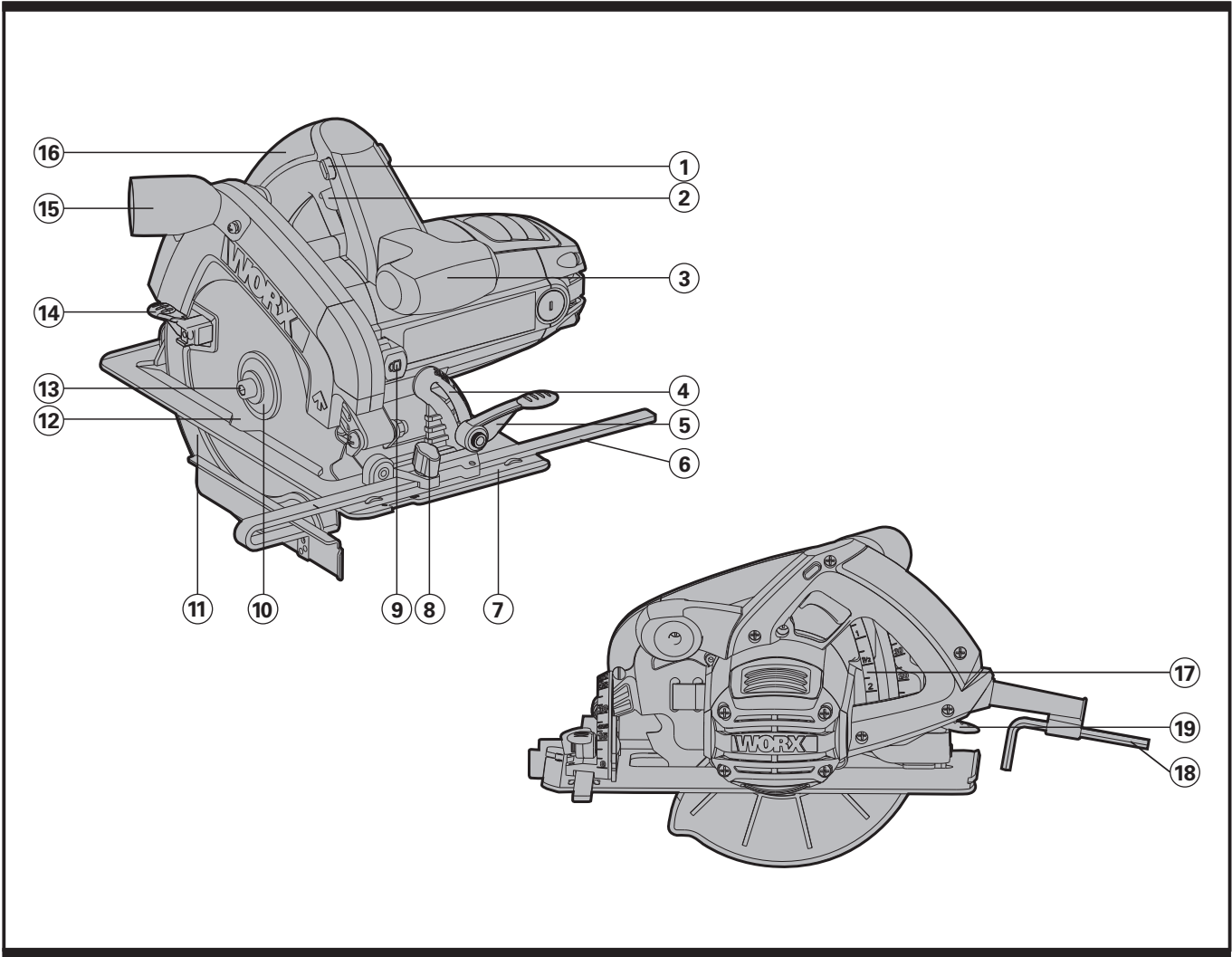

Circular saw

WX441 WX441.1

-
- 1. LOCK-OFF BUTTON**

 - 2. ON/OFF SWITCH**

 - 3. FRONT HANDLE**

 - 4. BASE PLATE ANGLE SCALE**

 - 5. BASE PLATE BEVEL LOCK**

 - 6. PARALLEL GUIDE**

 - 7. BASE PLATE**

 - 8. PARALLEL GUIDE LOCK KNOB**

 - 9. SPINDLE LOCK BUTTON**

 - 10. OUTER FLANGE**

 - 11. LOWER GUARD**

 - 12. SAW BLADE***

 - 13. BLADE BOLT**

 - 14. LOWER GUARD LEVER**

 - 15. VACUUM ADAPTER**

 - 16. REAR HANDLE**

 - 17. DEPTH OF CUT SCALE**

 - 18. HEX KEY**

 - 19. DEPTH OF CUT ADJUSTMENT LEVER**

 - 20. INNER FLANGE (See Fig. G)**
-

*** Not all the accessories illustrated or described are included in standard delivery.**

TECHNICAL DATA

	WX441	WX441.1
Rated voltage	220V-240V~50Hz/60Hz	
Rated power	1400W	
Rated no load speed	5000/min	
Max. cutting capacity		
90°	66mm	64mm
45°	47mm	45mm
Bevel capacity	0-51°	
Blade size	190mm	185mm
Protection class	□/II	
Weight	4.3kg	

NOISE AND VIBRATION DATA

A weighted sound pressure	L_{PA} 92.4 dB(A) K_{PA} = 3 dB(A)
A weighted sound power	L_{WA} 103.4 dB(A) K_{WA} = 3 dB(A)
Wear ear protection when sound pressure is over	85 dB(A) 
Typical weighted vibration	4.37m/s ² $K=1.5m/s^2$

ACCESSORIES

Vacuum adaptor	1
Parallel guide	1
Hex key	1
Blade: 190 mm x 30 mm x 24T (only for WX441)	1
Blade: 185 mm x 16 mm x 24T (only for WX441.1)	2

We recommend that you purchase your accessories from the same store that sold you the tool. Use good quality accessories marked with a well-known brand name. Choose the type according to the work you intend to undertake. Refer to the accessory packaging for further details. Store personnel can assist you and offer advice.

OPERATING INSTRUCTIONS

 **NOTE:** Before using the tool, read the instruction book carefully.

INTENDED USE:

The machine is intended for lengthways and crossways cutting of wood with straight cutting lines as well as bevel angles to 51° while resting firmly on the work piece.

1. DEPTH OF CUT ADJUSTMENT (See Fig A)

Lift the depth of cut lock lever and raise the saw body away from the base plate. Set the depth of cut with the scale and push the lever down to lock. Always add 3mm to your depth of cut so that the blade can cut through the material.

2. BASE PLATE ANGLE ADJUSTMENT (See Fig B1 & B2)

Turn the base plate bevel lock (5) in anti-clockwise direction to loosen the angle scale. Tilt the base plate away from the machine until the required cutting angle is adjusted on the angle scale (4). Tighten the bevel lock (5) by turning it in clockwise direction.

USING THE CIRCULAR SAW

1. SAFETY ON/OFF SWITCH (See Fig C)

Your switch is locked off to prevent accidental starting. Depress the lock off button then the on/off switch and release the lock off button. Your switch is now on. To switch off, just release the on/off switch. You can depress the lock-off button from either side of the button.

2. PARALLEL GUIDE ADJUSTMENT (See Fig D)

It is used for making cuts parallel to a workpiece edge at a chosen distance. Slide the parallel guide arm through the fixture to achieve the required cutting distance then tighten the lock knob to clamp. It can be used from both sides of the base plate. There is a cutting guide notch on the front of the base plate for using with a parallel guide. For straight cuts, use the 0° guide mark to align with your parallel guide scale. For a 45° bevel cut, use the 45° guide mark to align with your parallel guide scale. Securely clamp the parallel guide.

NOTE: It is best to carry out a trial cut.

3. CHANGING THE SAW BLADE (See Fig. E, F, G)

- Before any work on the machine itself, pull the mains plug.
- Wear protective gloves when mounting the saw

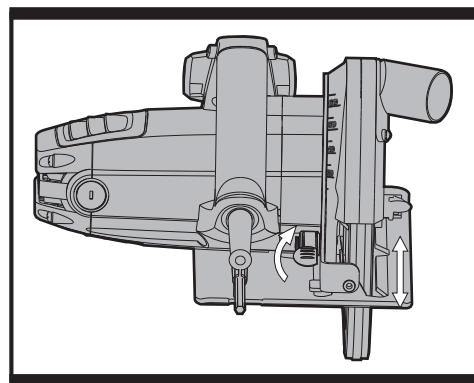

A

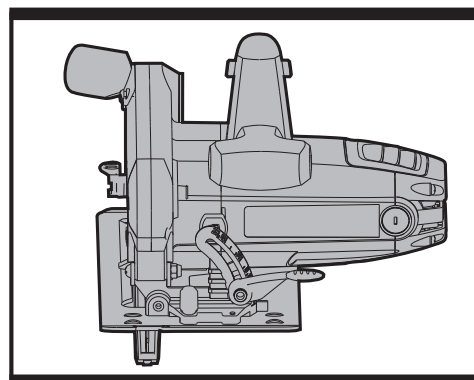

B1

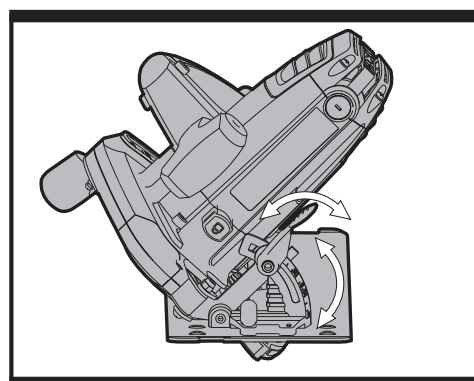

B2

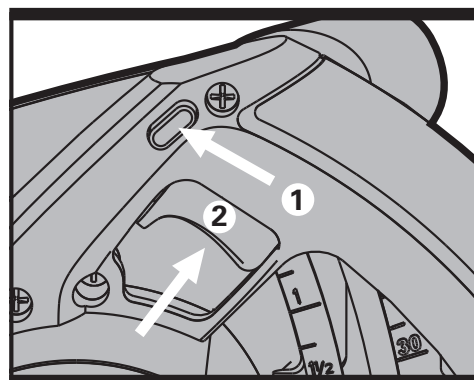

C

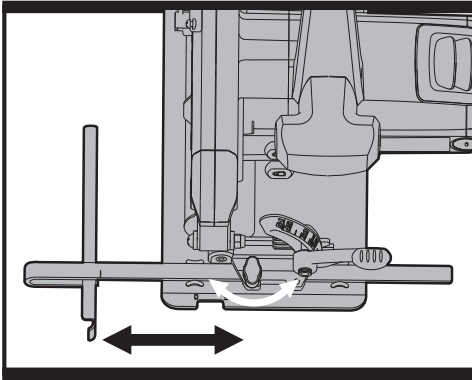

D

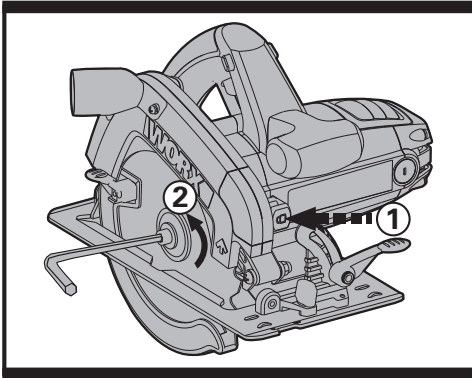

E

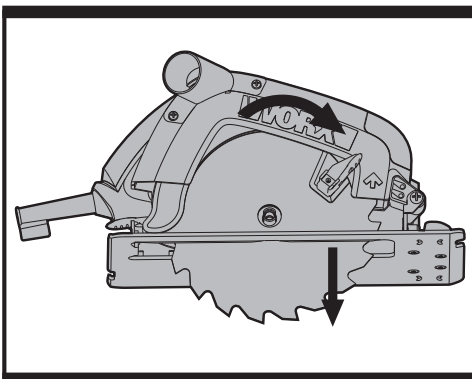

F

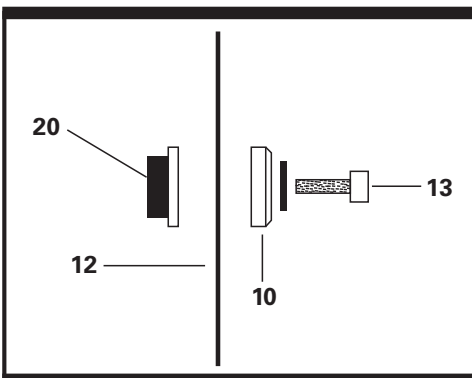

G

blade. Danger of injury when touching the saw blade.

- **Only use saw blades that correspond with the characteristic data given in the operating instructions.**
- **Do not under any circumstances use grinding discs as the cutting tool.**

For changing the cutting tool, it is best to place the machine on the face side of the motor housing.

REMOVING

Press the spindle lock button (9) and keep it depressed.

- The spindle lock button (9) may be actuated only when the saw blade is at a standstill.

Loosen the blade bolt (13) with the hex key (18).

Remove the outer flange (10). Tilt back the lower blade guard (11) and hold it firmly with the lower guard lever (14). Remove the saw blade (12).

MOUNTING

Clean the saw blade and all the clamping parts to be assembled. Tilt back the lower blade guard (11) and hold it firmly with the lower guard lever (14). Place the saw blade onto the inner flange (20). Assemble the outer flange (10) and the blade bolt (13). Use the hex key (18) to tighten the bolt (13) with 1/4 turn, more than finger tight.

- **Take care that the mounting positions of the inner flange (20) and outer flange (10) are correct.**
- **When mounting: Ensure that the cutting direction of the teeth (direction of arrow on saw blade) and the direction-of-rotation arrow on the blade guard match.**

4. DUST/CHIP EXTRACTION (See Fig.H)

Fasten the vacuum adapter (15) onto the dust extraction outlet until it latches. Additionally fasten the vacuum adapter (15) to the fixed guard with the two screws. Directly connect a suitable vacuum hose to the adapter.

• **The vacuum adapter must not be mounted**

when no external dust extraction is connected.

Otherwise there is danger of the extraction system becoming clogged.

Clean the vacuum adapter regularly to ensure optimum dust extraction. The vacuum cleaner must be suitable for the material to be worked.

5. HEX KEY STORAGE (See Fig I)

The hex key is stored at the rear of the circular saw. Put the key back when not in use.

6. ACCESSIBLE MOTOR BRUSH REPLACEMENT (See Fig. J)

There are two replaceable motor brushes which can be easily

accessed on either the front or back of the motor housing.

 **WARNING:** Disconnect the plug from the power source before making any adjustments, changing accessories, or storing power tools. Such preventative safety measures reduce the risk of starting the power tool accidentally.

 **ATTENTION: When servicing a tool, ALWAYS use only genuine replacement parts**

1. Locate the plastic motor brush access caps on either the front or back of the motor housing.
2. Remove the threaded access cap using a flat head screwdriver and turn in a counter-clockwise rotation to loosen. Do not apply excessive force as this may damage the access plug.
3. Remove the old motor brush.
4. Insert the new motor brush making sure that it is completely inserted into the brush holder.
5. Replace the access cap with the flat-head screwdriver turning clockwise to tighten.

WORKING HINTS FOR YOUR CIRCULAR SAW

If your power tool becomes too hot, please run your circular saw no load for 2-3 minutes to cool the motor.

Avoid prolonged usage at very low speeds.

Protect saw blades against impact and shock. Excessive feed significantly reduces the performance capability of the machine and reduces the service life of the saw blade. Sawing performance and cutting quality depend essentially on the condition and the tooth form of the saw blade. Therefore, use only sharp saw blades that are suited for the material to be worked.

MAINTENANCE

Remove the plug from the socket before carrying out any adjustment, servicing or maintenance.

Your tool requires no additional lubrication or maintenance. There are no user serviceable parts in your tool. Never use water or chemical cleaners to clean your tool. Wipe clean with a dry cloth. Always store your tool in a dry place. Keep the motor ventilation slots clean. Occasionally you may see sparks through the ventilation slots. This is normal and will not damage your power tool. If the supply cord is damaged, it must be replaced by the manufacturer, its service agent or similarly qualified persons in order to avoid a hazard.

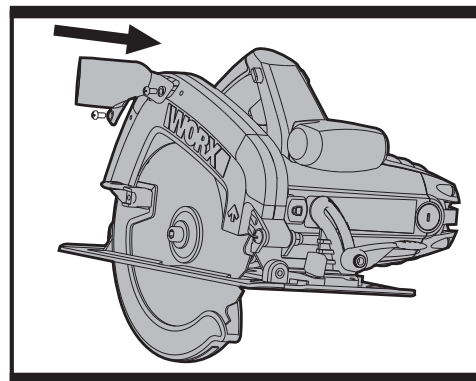

H

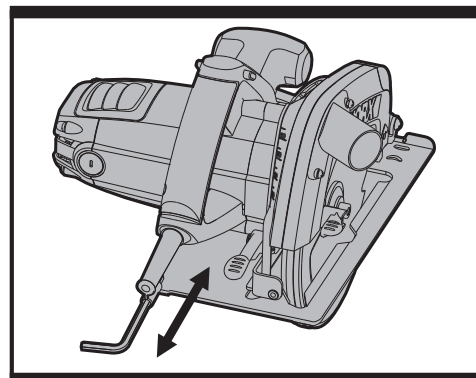

I

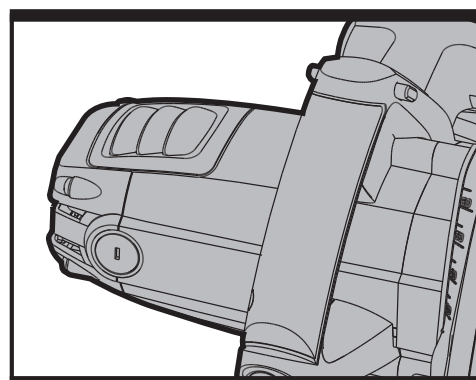

J

WORX
you've got the power