

TWIN-DRIVE REEL MOWER

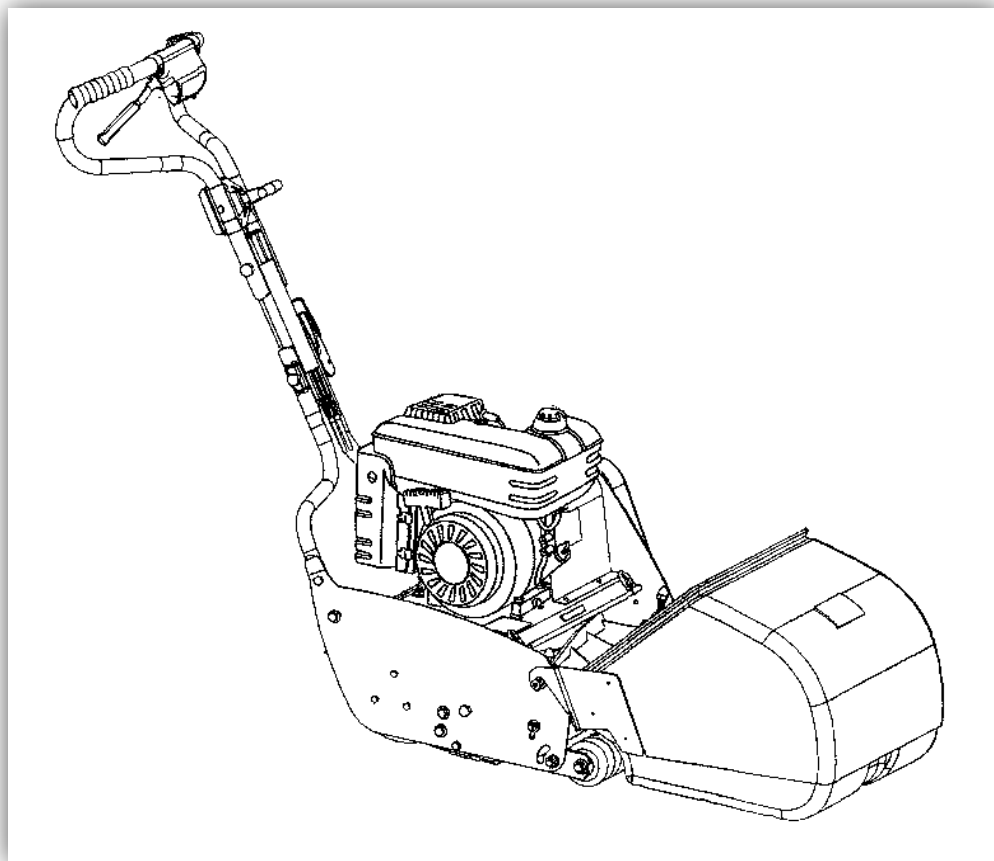

OWNERS MANUAL

LIST OF CONTENTS

INTRODUCTION	1
COMPLIANCE	1
SAFETY PRECAUTIONS.....	2
SYMBOLS.....	4
OPERATING THE REEL MOWER.....	5
OPERATOR PRESENCE CONTROL (OPC)	5
IDENTIFICATION OF CONTROLS	5
HANDLEBAR ADJUSTMENT	6
CUTTING HEIGHT ADJUSTMENT	6
CUTTING CYLINDER TO BOTTOM BLADE ADJUSTMENT	6
GRASS CATCHER	7
MAINTENANCE	8
CLEANING AND STORAGE.....	12
GRASS CUTTING FAULTS	13
TROUBLESHOOTING.....	14
WARRANTY	15

INTRODUCTION

The 'Twin-Drive' Reel Mower is a precision built machine, designed for a high quality of finish and long service life. The way in which the machine is operated and maintained will have a profound effect on its performance and reliability.

This manual contains advice on the safe operation of your 'Twin-Drive' Reel Mower, which is offered for the guidance and protection of all those operating and servicing the machine. In the pursuit of continuous development and product improvement, the Supplier reserves the right to alter specifications without notice.

COMPLIANCE

The Twin Drive Reel mowers have been tested for Noise Emission in accordance with Annex H of UNI EN 836:2003

Test Results

400 B 2.4	500 B 2.4	500 Golf B 4.0	660 B 4.0	500 H 5.5	500 Golf H 5.5	660 H 5.5
95 db(A)	96 db(A)	97db(A)	97 db(A)	96 db(A)	97db(A)	97 db(A)

The Twin Drive Reel mowers have been tested for Vibration values in accordance with EN 1033:1995

Test Results

400 B 2.4 $a_{hw,x} = 3.12 \text{ m/s}^2$ $a_{hw,y} = 3.73 \text{ m/s}^2$ $a_{hw,z} = 3.74 \text{ m/s}^2$	500 B 2.4 $a_{hw,x} = 4.04 \text{ m/s}^2$ $a_{hw,y} = 1.52 \text{ m/s}^2$ $a_{hw,z} = 2.17 \text{ m/s}^2$	500 Golf B 4.0 $a_{hw,x} = 3.93 \text{ m/s}^2$ $a_{hw,y} = 0.61 \text{ m/s}^2$ $a_{hw,z} = 2.25 \text{ m/s}^2$	660 B 4.0 $a_{hw,x} = 5.25 \text{ m/s}^2$ $a_{hw,y} = 1.19 \text{ m/s}^2$ $a_{hw,z} = 2.34 \text{ m/s}^2$
500 H 5.5 $a_{hw,x} = 5.52 \text{ m/s}^2$ $a_{hw,y} = 1.80 \text{ m/s}^2$ $a_{hw,z} = 3.49 \text{ m/s}^2$	500 Golf H 5.5 $a_{hw,x} = 5.76 \text{ m/s}^2$ $a_{hw,y} = 1.98 \text{ m/s}^2$ $a_{hw,z} = 2.15 \text{ m/s}^2$	660 H 5.5 $a_{hw,x} = 7.31 \text{ m/s}^2$ $a_{hw,y} = 1.21 \text{ m/s}^2$ $a_{hw,z} = 2.48 \text{ m/s}^2$	

SAFETY PRECAUTIONS

READ THIS MANUAL BEFORE USING THE REEL MOWER, IT IS ESSENTIAL THAT OPERATORS STUDY IT FOR THEIR OWN SAFETY.

THE FOLLOWING PRECAUTIONS MUST BE TAKEN TO HELP PREVENT ACCIDENTS. A CAREFUL OPERATOR WHO USES COMMON SENSE IS THE SAFEST OPERATOR.

1. Read the instructions carefully. Be familiar with the controls and use of the equipment.
2. Never allow children or people unfamiliar with these instructions to use the machine.
3. Never operate the machine while people or animals are nearby.
4. The operator or user is responsible for accidents or hazards occurring to other people or property.
5. While mowing, always wear substantial footwear and long trousers. Do not operate the mower when barefoot or wearing open sandals.
6. Thoroughly inspect the area where the mower is to be used and remove all stones, sticks, wires, bones and any other foreign objects.
7. Check that the mower is in good working order before using. Always visually inspect to see that the cutting blade, blade bolts and cutting cylinder are not worn or damaged and regularly check that all nuts, bolts, linkages and connections are tight and secure. Repair or replace excessively worn or damaged components with genuine TWIN DRIVE Spare Parts only.
8. Always add fuel before you start mowing. Refuel and lubricate outdoors only. Never remove the fuel cap or attempt to add fuel while the engine is running. Thoroughly clean any fuel spillages before starting the engine. After refuelling or topping up with engine oil, ensure that the filler caps are replaced securely.
9. Do not operate the mower in a confined space where dangerous carbon monoxide fumes can collect.
10. Mow only in daylight hours or in good artificial light.
11. Replace worn or faulty silencers.

SAFETY PRECAUTIONS

12. Never cut grass while walking backwards.
13. Always wear suitable eye protection and ear muffs when operating the mower.
14. When mowing on slopes, only mow across the face, never up and down. Exercise extreme caution when changing direction and do not attempt to mow excessively steep gradients.
15. Never lift or carry the mower while the engine is running.
16. Keep hands and feet well clear of rotating blades and components.
17. Always stop the engine when you leave the mower unattended and disconnect the cutting reel drive when crossing roads, pathways or gravel drives.
18. Always stop the engine and disconnect the spark plug before attempting to clean the mower, un-block the cutting mechanisms, carry out maintenance or repairs, inspecting the mower after abnormal vibrations or after striking a foreign object.
19. Do not adjust throttle or governor settings, as this will have a detrimental effect on the mower's cutting ability and ultimately shorten the mower's working life.
20. Store fuel in a cool place away from direct sunlight in a suitable container.
21. Never operate the mower with defective guards, shields or without safety protection devices in place and in good working order.
22. Disengage drive to the cutting reel when transporting or not in use

HEALTH & SAFETY AT WORK: This reel mower has been designed and constructed so that, in so far as reasonably practical, it will not endanger the safety and health of those working with it, This is however subject to the machine being properly used and maintained according to the conditions stated in this manual and elsewhere, which have been found necessary as a result of the research and testing of the Supplier.

SYMBOLS

MEANING OF THE SYMBOLS SHOWN ON THE MOWER



Warning



Read Operating Instructions before starting operations



Be careful of object thrown from the mower



Keep other people away from the danger zone



Disconnect spark plug before carrying out any maintenance



Attention – Danger Keep hands and feet away from cutting blades



Be careful of hot surfaces



Attention – Danger Do Not touch hot surfaces

OPERATING THE REEL MOWER

SAFETY NOTICE

WARNING: PREVENT ACCIDENTS

Before operating the mower it is essential that:-

- The operator reads and understands this manual.
- The daily maintenance checks have been properly carried out and the mower is in good working order.
- The operator should wear safety clothing and eye protection. Failure to do so could result in damage and risk to health and safety.

OPERATOR PRESENCE CONTROL (OPC)

Drive to the cutting cylinder is only possible when the operator actuates the reel clutch lever 'Y'. If the operator releases the lever, the drive to the cutting cylinder is disengaged.

IDENTIFICATION OF CONTROLS

Throttle Control Lever

The throttle control lever is located at the top the central handle tube. To start a cold engine fitted with a choke system, push the throttle control lever forward and move the choke lever situated on the carburettor to fully on position. After starting, slowly move the choke lever to the run position. Do not use the choke when starting warm engine. Note that the engine speed dictates the speed and operation of travel and cutting reel.

Reel Clutch Lever

The reel clutch lever 'Y' is located on the LH side of the upper handlebar 'Z' and is sprung to the disengage position. Squeeze the lever toward the handlebar to engage the drive to the cutting cylinder. Release the lever to disengage the drive to the cutting cylinder.

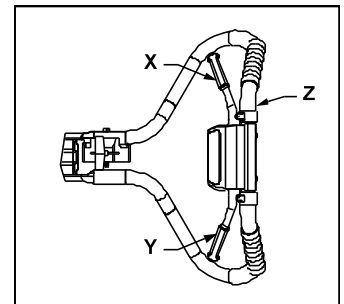

Roller Clutch Lever.

The roller clutch lever 'X' is located on the RH side of the upper handlebar 'Z' and is sprung to the disengage position. Drive to the rear roller is engaged when the lever is squeezed towards the upper handlebar. Releasing the lever disengages drive to the rear roller. When the reel and rear roller clutch Levers are squeezed both levers 'X' and 'Y' are interlocked in position. The levers remain engaged if any one of the levers is held squeezed. This enables one hand operation of the mower. Both drives are disengaged with the release of the levers.

OPERATING THE REEL MOWER

Recoil Start Handle.

Refer to the engine manufacturer's owners' handbook for details.

HANDLEBAR ADJUSTMENT

The clutch cables and levers are factory fitted to the upper handle and mower. The upper handle assembly is transported separated at the handlebar pivot point. On assembly, remove the handle locking lever, position the upper handle assembly, and fit the handle locking lever and clamp the upper handle in place. The height and position of the handlebar may be changed to suit individual operators requirements by loosening the bolts retaining the lower handlebar to the mower frame and pivoting it in the slot provided. The nuts and bolts must be secured in the position required.

CUTTING HEIGHT ADJUSTMENT

The cutting height is gauged by the position of the front and rear rollers. It is variable between 7 - 30mm and adjusted by means of a plastic handwheel. The cutting height is increased by rotating the handwheel in a clockwise direction and vice-versa. If a particular cutting height is required it is necessary to bridge the rear and front rollers and measure the normal height to the cutting point of the bottom blade and adjusting the handwheel to obtain the correct height of cut.

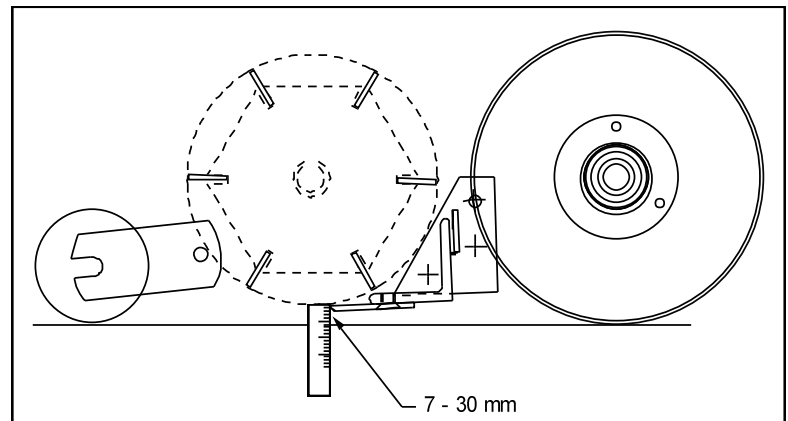

CUTTING CYLINDER TO BOTTOM BLADE ADJUSTMENT

It is essential that the relationship between the bottom blade and cutting cylinder is kept in good adjustment and that cutting edges are kept sharp to ensure good cutting performance, minimum power consumption and prolonged life for the cutting edges. Carry out the following procedures before commencing work and re-check the settings every 2-3 hours of mowing or when the cutting performance is noticeably reduced.

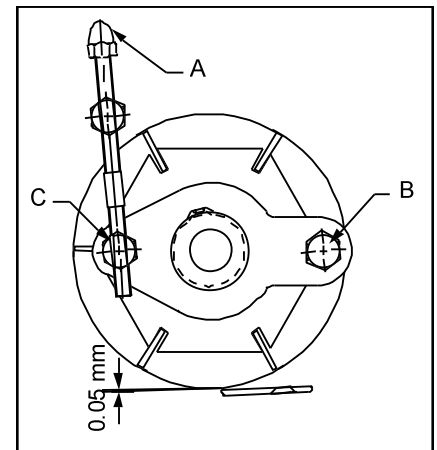

OPERATING THE REEL MOWER

Razor Cut System

Check that the cutting cylinder is correctly set in relation to the bottom blade by a piece of 2 thou (0.05 mm) shim between the cutting cylinder and the bottom blade. Carefully rotate the cylinder by hand and check that the shim is being touched by points along the length of the blade. Hold the shim flat on the bottom blade:-

If adjustment is necessary, proceed as follows:-

Turn adjusting screw 'A' in a clockwise direction each end alternatively, whilst rotating the cutting cylinder, with the shim on the bottom blade and is in fleeting contact with the cutting cylinder along its entire length. Re-check this procedure making marginal adjustments to screw 'A' as necessary.

NOTE:

There should always be a clearance of 2 thou (0.05 mm) between the bottom blade and cutting cylinder to create a scything cut for a better finish. This clearance also eliminates the noise created by the blades. DO NOT over tighten the bearing housing retaining nyloc nuts B and C.

When the grass is not being cut cleanly it will be necessary to regrind the front of the bottom blade. This procedure must be carried out by your authorised service agent on a quality, well maintained bottom blade grinding machine. If the wearing is excessive both the cutting cylinder and bottom blade will need regrinding.

GRASS CATCHER

Always shut off the engine whilst fitting or removing the grass catcher. The Twin Drive Reel Mower can be operated with the grass catcher fitted or removed. Generally the quality of sward will be improved with the grass catcher removed, hence re-clipping the grass. To fit the grass catcher, position the catcher in front of the mower and support the catcher by its front handle and its top edge. Lift the catcher into position engaging the hooks over the catcher studs at each end of the mower frame. Finally lower the catcher into place, ensuring it is sitting level on the mower. Reverse this procedure to remove the catcher.

IMPORTANT PREVENT DAMAGE: Regular maintenance is essential for the continued safe operation of the machine. Correct servicing will prolong the working life of the machine and safeguard the Twin Drive Warranty. Always fit genuine 'Twin Drive Service Parts' as these are accurately matched to the required duty.

Engine

Refer to the manufacturer's operators' manual for engine maintenance information.

Fuel

If the fuel has to be drained for maintenance or any other reason, this should be done outdoors.

Check engine oil level

Before the first use, every Twin Drive mower will require the addition of engine oil, as they leave the factory in a 'dry' condition. Engine oil requires changing after the initial first five hours of use, and then every 50 hours of normal use and 25 hours of heavy use thereafter. With the mower in a level position, remove the oil dipstick, if the engine oil level is below the minimum mark on the dipstick, top up with the correct grade of engine oil to the full mark on the dipstick. DO NOT OVER FILL. Then screw the dipstick securely back into place.

Clean the air cleaner

Remove and clean the air filter cartridge at three monthly intervals or every 25 hours of use. The air filter cartridge may require servicing more often under dusty operating conditions. To service the air cleaner cartridge, follow the procedures. Loosen the screws and remove the cartridge. Blow a gentle air line through the cartridge in the opposite direction to normal engine operation. If the cartridge is excessively dirty, it should be replaced.

Check spark plug

Clean and reset the spark plug gap every 100 hours of operation. Remember, in small engines, difficult starting and erratic running is most often attributable to a dirty, oily or carbonated spark plug. Do not file or sand blast the spark plug electrode but clean by scraping or wire brushing, then cleaning with a commercial solvent.

Rotating screen

Through prolonged operation, the rotating screen may become clogged with grass and debris. Clean the screen in line with the engine manufacturer's recommendations to avoid over heating and possible engine damage.

Throttle control

Lubricate the throttle cable by applying a light oil to the top of the inner wire and allowing it to gravity drain down the inside. The throttle control lever quadrant should have a medium grease smeared over it to protect it from corrosion and to give a smooth operation.

Clutch cables and pivots

Lubricate the clutch cable by applying a light oil to the top of the inner wire and allowing it to gravity drain down the inside. The cable pivot also requires occasional lubrication to allow free movement of the mechanisms.

Fasteners and linkages

Check that all nuts, bolts, pins and linkages are secured correctly in place and are in good condition.

Drive chain tension

It will be necessary after the initial 5 hours and every 25 hours of use thereafter to check and adjust the tension of the drive chains. The chain guard must be removed from the mower frame to get access to the transmission system. Wear in the reel drive chain is compensated for by the sprung chain tensioner shoe. As the motor / clutch and clutch / roller chains stretch, the clutch assembly must be moved in order to obtain the correct slack in each chain. The nut at the bottom of the clutch mount plate must be slackened and the clutch assembly moved forward and down to take out the excess slack. There should be approximately 3 - 5mm of slack in each chain for correct adjustment. It would be worthwhile at this stage to inspect the bearings and sprockets for excessive wear. Replace worn or damaged parts before further use.

Flexible coupling

Remove the drive shaft cover and inspect the flexible coupling 'spider' for signs of wear every 50 hours of operation.

General Lubrication

Grease nipples are provided in the cutting cylinder bearings (and roller bearing housings on Golf & Sports models) and should be greased every 25 hours. The drive chains should have a small amount of grease applied to each one to prevent seizure and prolong the chain life.

Clutch cable adjustment

The Reel Mower operating levers feature a '**Hold In**' interlatch that allows single handed operation of the mower. After several hours of operation the clutch cables may require adjustment to obtain the correct drive. This may be due to either the clutch cable

MAINTENANCE

stretching or the clutch plates wearing, therefore not allowing sufficient travel on the clutches to engage the drives. There is adjustment in the cable assemblies to accommodate the wear. The following procedures should be followed. Remove the shaft cover and put to one side with the fasteners.

The **Reel clutch** can be adjusted, with the cable inline adjuster 'D'. Firstly loosen the reel clutch cable inline adjuster 'D', then tighten one turn at a time and re-check the roller clutch engagement. Continue this procedure until the reel drive is fully engaged. When the cable is correctly adjusted, the lever should engage the 'hold in' detent .

The **Roller clutch** can be adjusted, with the cable inline adjuster 'E' and also by the locknut 'F' fitted to the pull rod.

Firstly loosen the roller clutch cable inline adjuster 'E', then tighten one turn at a time and re-check the roller clutch engagement. The correct engagement is achieved when the lever engages the 'hold in' detent with full clutch engagement. If this adjustment is not attainable with this method it is necessary to remove the 'slack' from the system by tightening the locknut 'F' on the pull rod a turn at a time until the required movement is achieved.

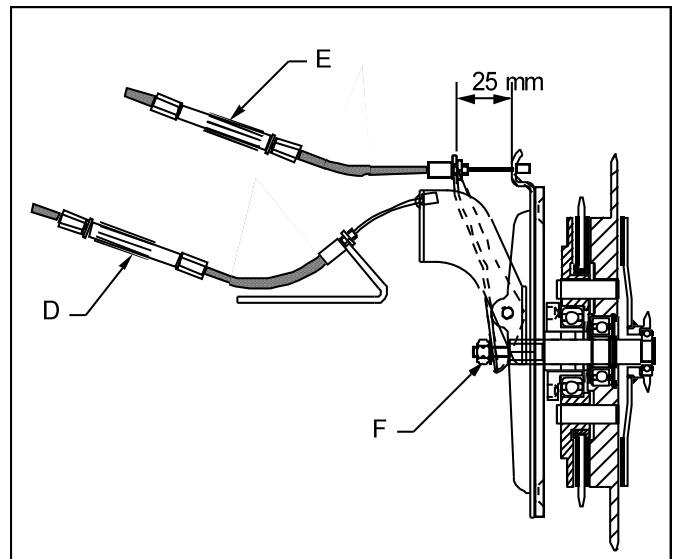

Once the adjustments to the clutch cables have been made and the mower drive is correct, finally replace the shaft cover.

Grass thrower adjustment

The grass thrower will require adjustment in certain grass conditions or after prolonged use of the mower as the cutting edges wear. This will be noticeable by the reduced efficiency to catch grass and to fill the catcher. The closer that the grass thrower is to the periphery of the cutting reel, the better the catching ability and the harder the grass is thrown.

First slacken the two retaining screws and pull the grass thrower forward to reduce the gap between it and the cutting cylinder without it touching as this will create unnecessary noise and wear on the cutting edges. A little trial and error will soon achieve the optimum position. Re-tighten the

retaining screws while holding the grass thrower in position. If the grass throwing ability is not improved by these adjustments it will be necessary to take the mower to an authorized service agent for checking over and possible modification to the grass thrower plate.

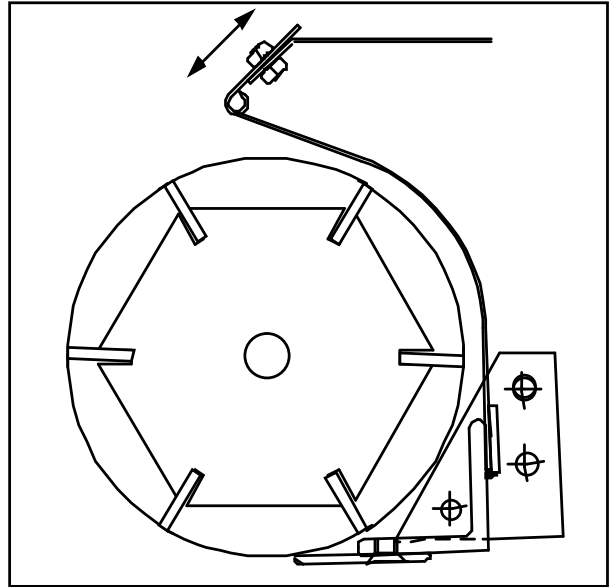

Catcher

Check the grass catcher frequently for wear or deterioration.

Maintenance

Replace worn or damaged parts to keep the mower in a safe condition.

When carrying out any adjustment or maintenance, take care to prevent entrapment of the fingers between moving blades and fixed parts of the mower.

CLEANING AND STORAGE

There is a direct relationship between the mower's life and the care and attention given to the mower both during and after operation. After use it is important that the mower is thoroughly cleaned down and inspected so that it will be in good working order the next time it is required. Disconnect the spark plug lead and thoroughly clean the engine, underside of the chassis, rollers and grass catcher. Where water is used under pressure it is important that all the grease and lubrication points are lubricated to force out the water that can sit in the bottom of bearings and chains prior to storage. Do not use a water hose around the engine as this may contaminate the fuel or enter the ignition system and result in poor engine performance and starting problems.

Muffler

Always clean around the muffler area regularly to reduce the risk of fire and damaging the mower. Brush the grass, dirt or combustible debris from the muffler.

Always store the mower on a flat, level surface.

End of Season storage:

After each mowing season or if the mower is not going to be used for **30 days** or more, it is recommended that the fuel shut off valve be closed off (where fitted) and the fuel tank be drained as fuel has a shelf life of only about 30 days. The mower should then be started up and run until all of the fuel left in the system is used. Run the engine until it is warm and drain the engine oil and refill with the correct grade to the required level. Remove the spark plug and pour 15cc of engine oil into the cylinder, crank slowly to distribute the oil and replace the spark plug. Store the mower in a clean dry area away from direct sunlight as this will have an aging effect on the plastic catcher assembly.

Adjust the cutting cylinder away from the bottom blade and apply a thin layer of grease to the cutting edges to prevent corrosion through the storage period. If possible, spray the mower with a thin film of light oil to protect it.

Safety:

To reduce the fire hazard keep the engine, muffler and petrol storage free of grass, leaves or excessive grease. Never store the mower with petrol in the tank inside a building where fumes can reach an open flame or spark.

GRASS CUTTING FAULTS

FAULT	POSSIBLE CAUSE	REMEDY
Ridge lines in the cut across the direction of travel.	• Forward speed too high.	• Reduce engine rpm.
	• Cylinder speed too slow.	• Reduce forward speed.
	• Height of cut too low.	• Raise height of cut.
Some uncut or poorly cut strands of grass.	• Cutting cylinder is partially out of contact with the bottom blade.	• Re-adjust cutting cylinder to bottom blade.
	• Cutting cylinder is in heavy contact with the bottom blade.	• Re-adjust cutting cylinder to bottom blade.
	• Height of cut is too high.	• Lower height of cut setting.
	• Cutting edges of cutting cylinder / bottom blade are rounded.	• Regrind cutting edges.
Lines of uncut or badly cut grass in direction of travel.	• Tramlining of cutting edges due to heavy contact caused by poor cylinder / blade adjustment.	• Regrind cutting edges.
	• Bottom blade in ground contact.	• Raise height of cut.
	• 'Nose down' attitude of bottom blade.	• Re-adjust height of cut.
•	•	
Scalping.	• Undulations too severe for height of cut setting.	• Raise height of cut.
Excessive bottom blade wear	• Bottom blade in heavy ground contact.	• Raise height of cut.
	• Cutting edges of cutting cylinder / bottom blade are rounded.	• Regrind cutting edges.
	• Cutting cylinder is in heavy contact with the bottom blade.	• Re-adjust cutting cylinder to bottom blade.
	• Damaged cutting cylinder or bottom blade.	• Regrind or replace as necessary.

If fault persists, consult your authorised Twin Drive Service Agent.

TROUBLESHOOTING

FAULT	POSSIBLE CAUSE	REMEDY
Engine does not start, runs erratically or experiencing power loss.	<ul style="list-style-type: none"> Throttle not in choke / start position. 	<ul style="list-style-type: none"> Move throttle to choke / start position
	<ul style="list-style-type: none"> Fuel tank empty or fuel shut off valve closed. 	<ul style="list-style-type: none"> Fill tank with recommended fuel grade and open fuel shut-off valve.
	<ul style="list-style-type: none"> Air cleaner element is dirty. 	<ul style="list-style-type: none"> Service or replace air cleaner
	<ul style="list-style-type: none"> Spark plug loose. 	<ul style="list-style-type: none"> Tighten spark plug.
	<ul style="list-style-type: none"> Spark plug cable disconnected. 	<ul style="list-style-type: none"> Refit cable to spark plug.
	<ul style="list-style-type: none"> Defective spark plug. 	<ul style="list-style-type: none"> Replace damaged spark plug.
	<ul style="list-style-type: none"> Spark plug gap incorrect. 	<ul style="list-style-type: none"> Replace damaged spark plug. Refer to Engine Manual.
	<ul style="list-style-type: none"> Carburettor is flooded with fuel. 	<ul style="list-style-type: none"> Move throttle to 'stop' position, pull the starter cord 5 - 6 times, move throttle to 'run' and start engine.
	<ul style="list-style-type: none"> Dirt, water or stale fuel in the tank. 	<ul style="list-style-type: none"> Drain and clean fuel tank. Refill with clean fresh fuel before starting.
	<ul style="list-style-type: none"> Vent hole in the filler cap is blocked. 	<ul style="list-style-type: none"> Clean or replace filler cap.
<ul style="list-style-type: none"> Spark plug gap too small. 	<ul style="list-style-type: none"> Refer to engine manual. 	
<ul style="list-style-type: none"> Air cleaner is element dirty. 	<ul style="list-style-type: none"> Service or replace air cleaner. 	
Engine skips at high speed.	<ul style="list-style-type: none"> Blocked engine cooling fins and air passages. 	<ul style="list-style-type: none"> Remove debris from around engine.
Engine idles poorly.	<ul style="list-style-type: none"> Cooling air flow restricted. 	<ul style="list-style-type: none"> Remove debris from around engine.
Engine overheats.	<ul style="list-style-type: none"> Incorrect spark plug fitted. 	<ul style="list-style-type: none"> Refer to Engine Manual.
	<ul style="list-style-type: none"> Low engine oil level. 	<ul style="list-style-type: none"> Check oil level and top up if necessary.
Excessive vibration and / or noise.	<ul style="list-style-type: none"> Worn or damaged bearing(s). 	<ul style="list-style-type: none"> Remove and inspect suspect bearings, replace if necessary.
	<ul style="list-style-type: none"> Worn or damaged drive chains and / or sprockets. 	<ul style="list-style-type: none"> Remove and inspect suspect chains and sprockets, replace if necessary.
	<ul style="list-style-type: none"> Worn or damaged cutting reel or bottom blade. 	<ul style="list-style-type: none"> Inspect cutting reel and bottom blade for excessive wear or damage. Cutting edges will require regrinding or replacement by your authorised Twin Drive Service Agent.
Oil leaks from muffler or air cleaner.	<ul style="list-style-type: none"> Worn or damaged flexible coupling. 	<ul style="list-style-type: none"> Inspect and replace worn 'spider' if necessary.
	<ul style="list-style-type: none"> Engine oil sump over filled. 	<ul style="list-style-type: none"> Check oil level and drain excessive oil.
	<ul style="list-style-type: none"> Mower tipped or handled incorrectly. 	<ul style="list-style-type: none"> Check oil level, air cleaner and spark plug and correct as necessary.

If fault persists, consult your authorised Twin Drive Service Agent.

WARRANTY

The supplier warrants this Twin Drive Reel Mower to be free from defects in material and workmanship.

Subject to the following conditions, the Supplier will meet the cost of repairing or replacing any part(s) deemed to be defective when examined by an authorised Twin Drive Service Agent.

1. This warranty does not include the engine and batteries (if fitted), which are covered by separate manufacturers warranties.
2. For other items, this warranty will apply for a period of two years from the date of purchase for the original purchaser only, with the exception of domestic mowers that are used for commercial, institutional, industrial, rental or income producing purposes which are limited to 90 days of warranty.
3. This warranty excludes normal wear and tear, misuse, neglect, accidental damage or defects arising from failure to comply with the instructions as outlined in this Owner's Manual. Wearing parts such as reels, bottom blades and spark plugs which can be subjected to use beyond their normal working capacity are also excluded.
4. This warranty is void if parts other than genuine Twin Drive have been used or repairs carried out by other than authorised Twin Drive Service Agents.
5. This warranty does not cover the costs of transportation of any part(s) but does cover the labour / part costs incurred in repairing or replacing any defective part(s).
6. The supplier reserves the right to inspect any faulty part(s) in order to determine the validity of the warranty claim or for any other reason.
7. The supplier has no liability for any incidental, consequential or special damages and / or expenses resulting from any defect in their product.

These conditions do not affect the purchasers' statutory rights under the laws of the place, state or country of purchase.

If warranty service is required, contact your nearest authorised Twin Drive Service Agent.